

Apeiron™ LTE+ / E12 Power Box

LED Downlight System
For Elevators

Installation Guide

i2Systems®
ADVANCED LED LIGHTING

Thank you for purchasing the
Apeiron™ LTE+ LED Fixture
and **E12 Elevator Power Box!**

Support

If you have questions after reading this information or would like our advice on your project, call us before working with any product from i2Systems.

i2Systems Technical Support is available from 9 a.m. to 5 p.m. EST by phone at 1.860.567.0708 or email at support@i2systems.com.

A free copy of this installation guide is available online at www.i2systems.com along with these resources:

- Apeiron LTE+ A4390 Spec Sheet
- Power Box PS24V45W-E12 Datasheet

Copyright

Copyright © 2013 i2Systems. All Rights Reserved.

Trademarks

i2Systems, the i2Systems Logo, and Apeiron are either registered trademarks or trademarks of i2Systems.

Limitation of Liability

While every reasonable precaution has been taken in the preparation of this install guide, the author and publishers assume no responsibility for errors or omissions, nor for the uses made of the material contained herein and the decisions based on such use.

Product information is subject to change without notice.

IMPORTANT SAFEGUARDS

READ AND FOLLOW ALL SAFETY INSTRUCTIONS.

When using electrical equipment, basic safety precautions should always be followed including the following:

- Do not use outdoors.
- Do not let power supply cords touch hot surfaces.
- Do not mount near gas or electric heaters.
- The use of accessory equipment not recommended by manufacturer may cause an unsafe condition.
- Caution: LED lamp(s) are used in this equipment. To avoid damage: Do not operate the lamp in excess of rated voltage, protect lamp against abrasion and against liquids.
- Do not use this equipment for other than intended use.
- Operate this equipment within the specified temperature and environmental ranges.
- Equipment should be mounted in locations and at heights where it will not readily be subjected to tampering by unauthorized personnel.
- The E12 Power Box is for use only with i2Systems Apeiron LTE+ LED Fixtures.
- Do not install luminaire with other than the intended Class 2 power unit.
- Read and understand these installation instructions and safety labels before you begin installation.
- Turn off the power before installing or servicing the Fixtures or Power Box and/or connecting or disconnecting individual fixtures.
- Follow all national and local electrical and construction codes and regulations, including NEC Article 411.4. Conductors of Low Voltage Lighting Systems concealed or extended through a wall, floor, or ceiling shall be installed using any of the wiring methods specified in Chapter 3 (conduit) or shall be installed in accordance with Article 725.130.
- Avoid all temptation to disassemble the Fixture and/or Power Box because there are no serviceable parts and tampering could cause shock.
- Comply with the maximum voltage ratings of the Fixtures and Power Box.

SAVE THESE INSTRUCTIONS

Certifications



Introduction

Use these instructions to plan, install, and wire your new Apeiron LTE+ Fixture. Proper installation will ensure this Fixture will provide superior elevator lighting with minimal maintenance and electric consumption for many years.

WARNING: Only a qualified electrician should install i2Systems products.

While it may be tempting to skip sections, we assure you that reading this material will help you to avoid problems and speed up the installation process.

Identify all parts

- Familiarize yourself with the Fixture, Power Box, and associated accessories.

Mount the Power Box

- Power Box may be installed on the Cab Top or above the Drop Ceiling. For ease of wiring, be sure to centrally locate the Power Box.

Wire

- Using the supplied cables, wire the Cab in accordance with National and Local Electrical and Elevator Standards.

Install the Fixture

- Plug in the Fixture and insert into the Ceiling*.

Apply Power

- For Dimmable Model (E12D), set desired intensity.

*Assumes ceiling thru-holes are pre-cut.

Apeiron LTE+ Specifications



Watts:	4W/24V
Input Voltage:	28V DC Max. (24V DC Nom.)
Operating Temp:	-20°C to 30°C
Max Case Temp (Tc):	50°C
Humidity:	0 to 95% Non-Condensing

Fixture Dimensions

Top View

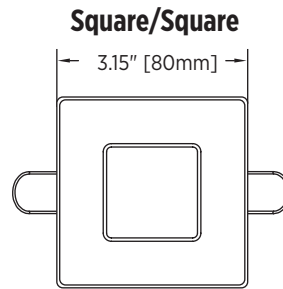
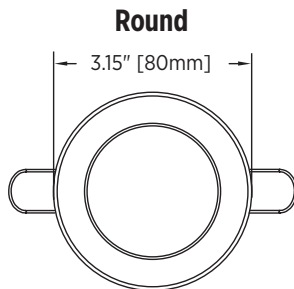

Side View

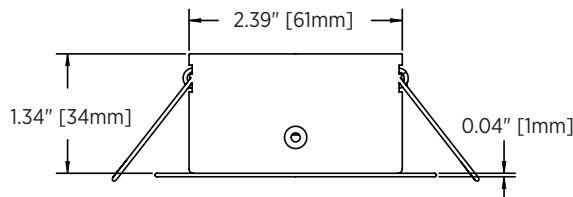

Power Box Specifications

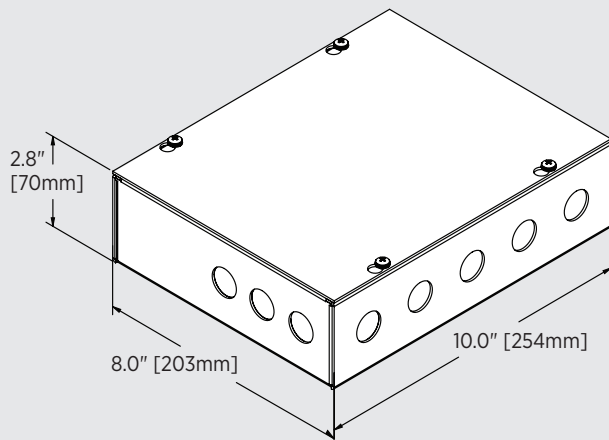

PS24V45W-E12/E12D

120V-240V AC Input

Powers up to 9 Apeiron LTE+ Fixtures.

E12D Model includes Dimming

System Layout

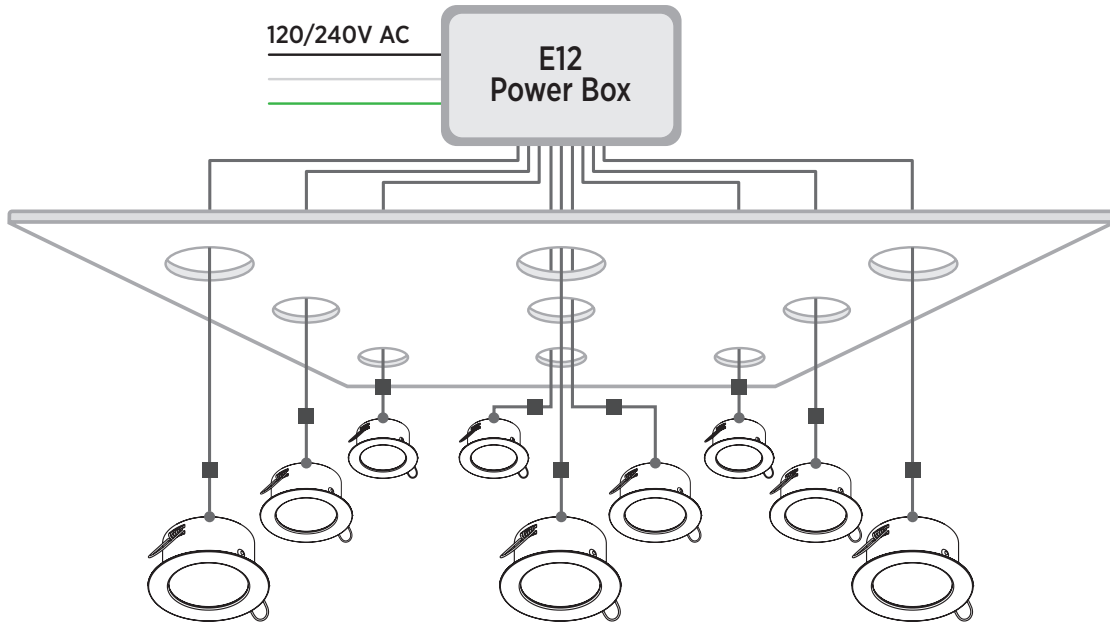

Cab Lighting Recommendation

Elevator Cab Capacity	Typical Light	Bright Light
2100 lb	6	9
2500 lb	6	9
3000 lb	6	9
3500 lb	6	9
4000 lb	6	9
4500 lb	9	12*
5000 lb	9	12*

*Requires two Power Boxes.

Installation Tips

- There should be no strain on the cables between the Fixtures and the Power Box. Use appropriate cable strain reliefs (not supplied with this Fixture) where necessary.
- If your state and local codes require conduit, install a junction box (or similar) over each light position and then connect the conduit as required.
- Always verify cab light levels with a light meter to ensure your system as installed meets Code.

Installation

Step 1: Mount Power Box

Install the Power Box in an easily accessible area, either on top of the cab or near the escape panel, centrally located to the Fixtures. Securely mount the Power Box before you begin any electrical work. Mounting hole locations are shown below.

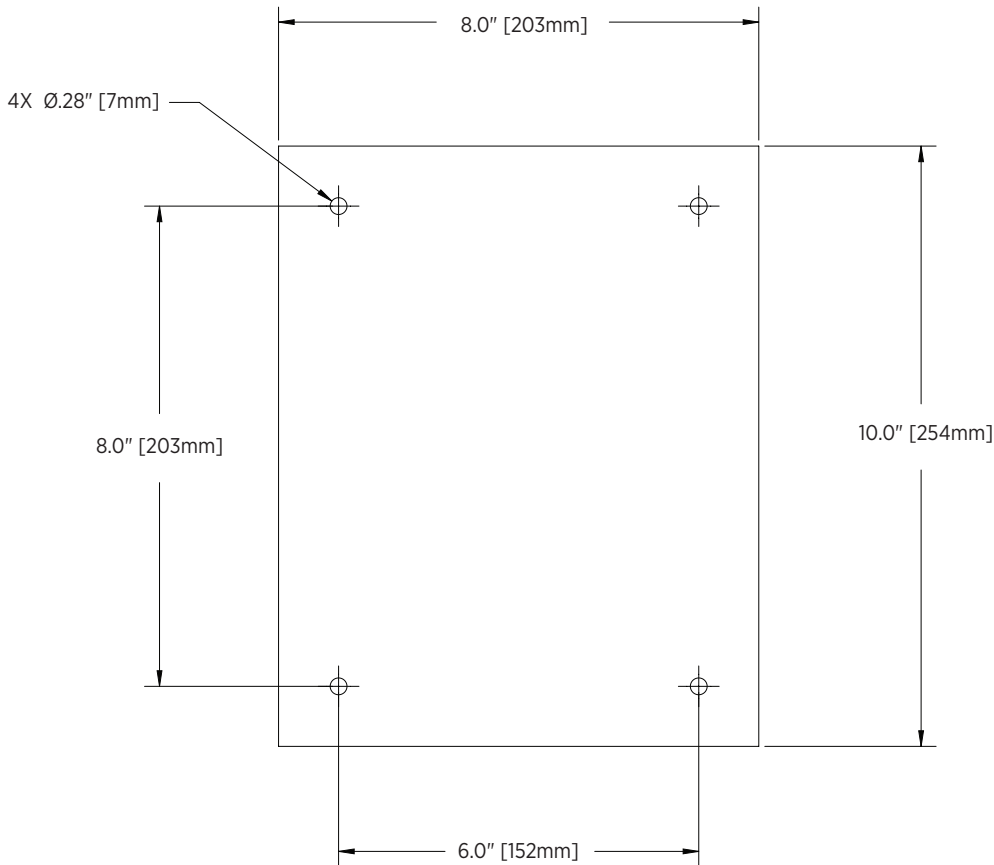

Step 2: Wire the Cab

Ensure all power is off prior to wiring the Cab. The Power Box operates on 120/240V AC. Refer to the wiring diagrams in this guide for wiring details.

To wire the Fixtures, use the included 6 ft cable to home run each Fixture to the Power Box, keeping in mind that some state and local codes require this cable to be installed within conduit.

Installation

Step 3: Install Fixtures

A) Bore one 2.75" [70mm] mounting hole per fixture if a mounting hole has not been provided:

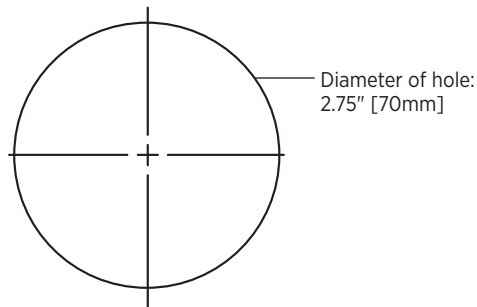

B) Plug Fixture into Wire Harness using supplied connector installed to the light. Be careful not to hang the fixture by the Cable.

C) Press back the spring clips on the Fixture and insert it in the mounting hole.

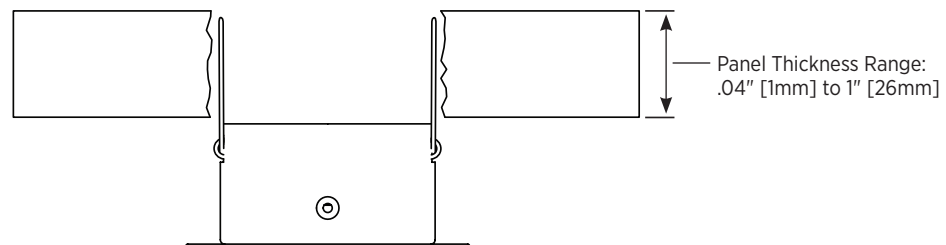

D) Carefully release the spring clips, keeping your fingers clear and allow the fixture to be pulled up into the ceiling.

E) Remove the Protective Film from the Fixture Trim & Lens.

E12 Power Box Setup (Top View)

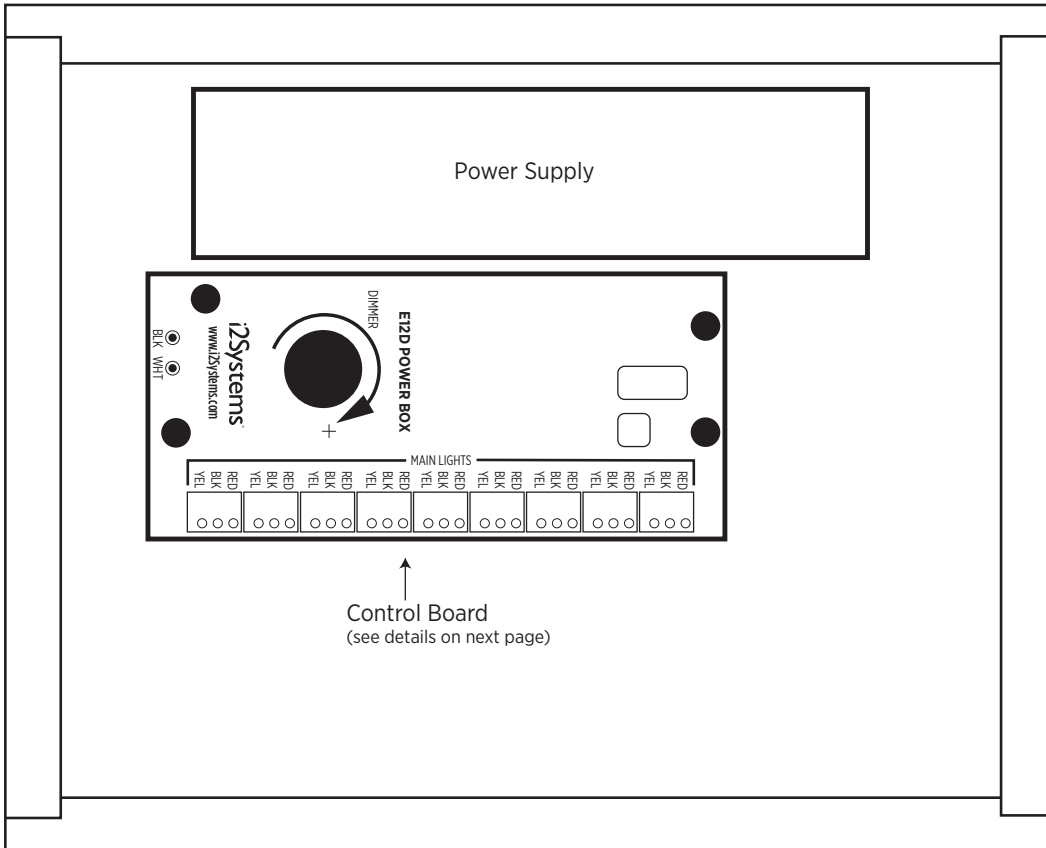

Operational Notes:

Power Supply

The Power Supply provides 24V DC power to the Control Board and lighting circuits.

Control Board

The Control Board provides both terminal blocks for simple wiring and system controls, including dimming available on E12D Model. See the next page for additional information.

Control Board Diagram (Top View)

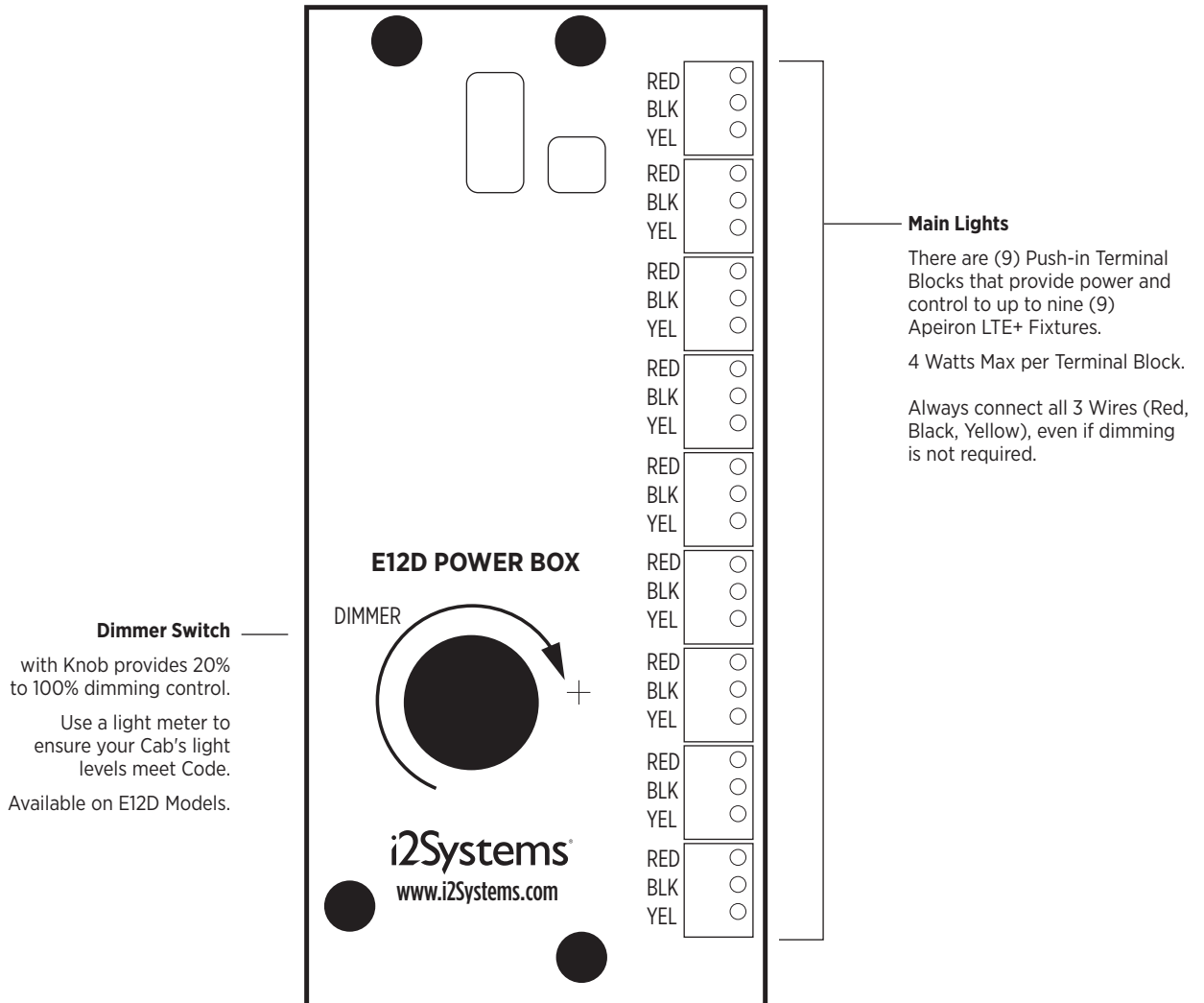

Block Diagram

Wiring the PS24V45W-E12D Power Box for 120/240V AC Input with Dimming

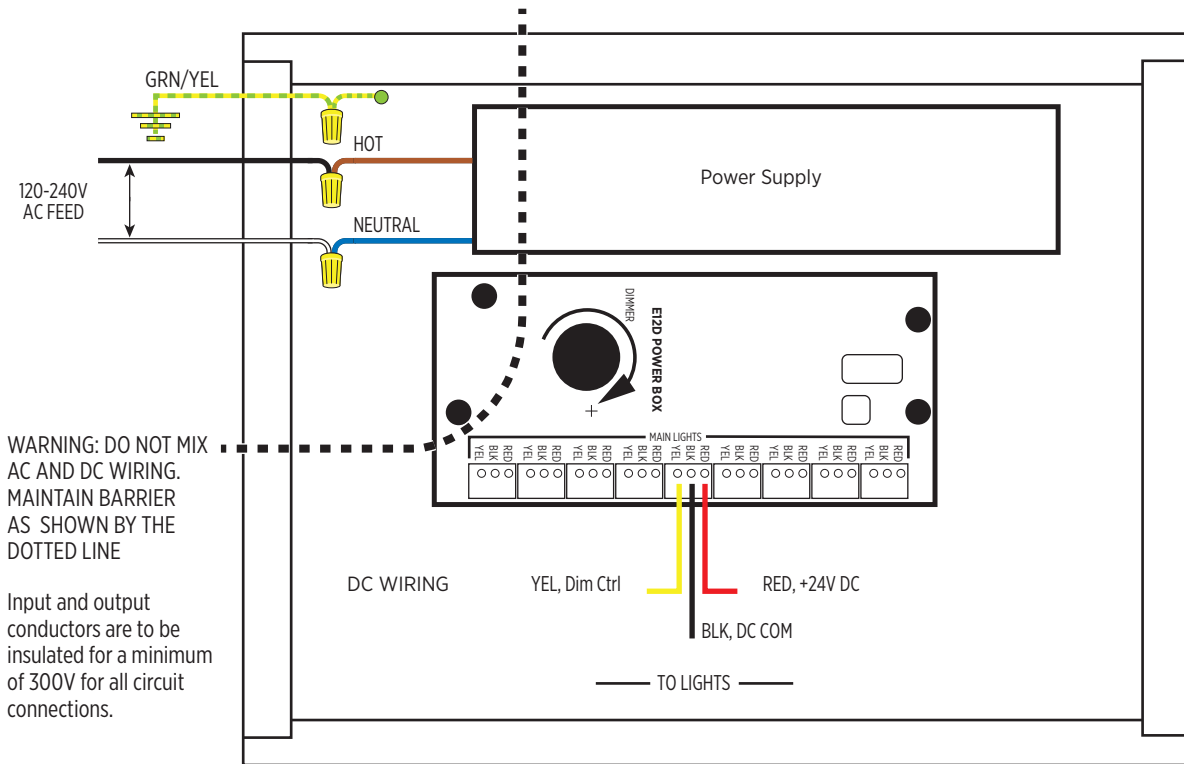

Light Hookup

Apeiron LTE+ Lights Home Run to each Terminal Block. There are 9 sets of Terminal Blocks, each with 3 conductors per Light. For simplicity, only 1 set is shown in this diagram. Always connect all 3 Wires (Red, Black, Yellow), even if dimming is not required.

To turn lights on and off, simply energize or de-energize the 120/240V AC Input to the E12 Power Box.

Frequently Asked Questions

Q: Can I connect the Apeiron LTE+ directly to line voltage?

A: No. Connecting the Apeiron LTE+ directly to line voltage or any voltage higher than 24V DC will damage the Fixture and void the warranty. Use i2Systems E12 Power Box to convert line voltage to the proper voltage.

Q: Are the Apeiron LTE+ Fixtures dimmable?

A: Yes. The Apeiron LTE+ includes dimming as a standard feature, provided they are used with the E12D Power Box. To adjust the light level, use the knob on the Control Board connected to the Fixture(s) you want to dim, keeping in mind that dimming too low may result in your Cab not meeting Code.

Q: Can I load the E12 Power Box to the specified Wattage (45W)?

A: Yes. The power supply installed in the E12 Power Box is rated for 60 Watts continuous operation, in which case the 45W specification (up to 9 lights) is already derated. Refer to the E12 Power Box Datasheet for additional details.

Q: How do I wire the Apeiron LTE+ to the Power Box?

A: Home run each Apeiron LTE+ Fixture to the Power Box using the included 6 ft Connectorized Cable, keeping in mind that some state and local codes require this cable to be installed within conduit.

Limited Warranty

1.1 Limited Warranty. Products are warranted to be free from defects in material and workmanship and to conform substantially to i2Systems' then-current (as of the date of Product shipment) user documentation and specifications for a period of one (1) year from the date of invoice (the "Warranty Period"), provided the Products are used under those operating conditions (including electrical values and environmental conditions) described in i2Systems' then-current user documentation and specifications for such Products. i2Systems shall not be liable under the foregoing warranty if Buyer fails to provide i2Systems with notice of the alleged defect during the Warranty Period.

1.2 Remedies. In the event a Product does not comply with the foregoing express warranty, Buyer may notify i2Systems within the Warranty Period and if so notified i2Systems will, at i2Systems' option: (a) provide a replacement for such Product or defective component or part thereof that has caused the warranty claim (such Product or defective component or part thereof that has caused the warranty claim, the "Warranty Item"); or (b) refund to Buyer the lesser of (1) the amount Buyer paid for the Warranty Item, or (2) Buyer's cost to replace the Warranty Item, in each case as determined by i2Systems in its sole and absolute discretion following receipt and inspection by i2Systems of the Warranty Item. For the avoidance of doubt, "provided a replacement for such Product or defective component or part thereof" expressly does not include any removal or reinstallation costs or expenses, including without limitation labor costs or expenses. All exchanged Warranty Items shall become the property of i2Systems. i2Systems may use either new or remanufactured, reconditioned or refurbished components or parts (if in like-new condition), or functionally equivalent components or parts, in the furnishing of replacement(s) for any Warranty Item. i2Systems' warranty flows only to Buyer of the products. If i2Systems chooses to replace the Product and is not able to do so because it has been discontinued or is not available, i2Systems may replace it with a comparable product.

1.3 Limitations. The foregoing warranty is limited, and does not extend to, and i2Systems shall incur no liability for: (a) lumen maintenance of the Products; (b) color shift of light output of the Products; (c) degradation or discoloration of the Product housing(s); (d) mechanical or cosmetic deterioration of the Products associated with normal wear and tear. For clarity and without limiting the generality of the foregoing, the foregoing warranty does not apply if a Product's light module continuously generates light at any intensity, regardless of whether such intensity has decreased since the date of first use of such Product [(viz., warranty coverage only applies in the event that such light module generates no light or generates light intermittently)]. This limited warranty only applies when the product has been properly wired and installed and operated within the electrical values, operating range and environmental conditions provided in the Specifications. This warranty does not apply to damage or failure to perform arising as a result of any Acts of God or from any abuse, misuse, abnormal use or use in violation of any applicable standard, code, or instructions for use including those contained in the latest National Electrical Code, the Standards for Safety of Underwriters Laboratory, Inc., the Standards for the American National Standards Institute or, in Canada, the Canadian Standards Association. This Warranty shall become void in the event any repairs or alternations not duly authorized by i2Systems in writing are made to the Product by any person.

Buyer shall convey with each Product distributed to end users this LIMITED WARRANTY, and if i2Systems determines that the appropriate remedy for a defective product is refund of Buyer's purchase price, Buyer shall refund to the end user (or arrange for the refund to the end user of) the full purchase price paid by the end user for such defective Product.

With respect to Products sold to the Buyer by i2Systems but not bearing i2Systems' name or sub-brand name, I2SYSTEMS MAKES NO WARRANTY OF ANY KIND, EXPRESS OR IMPLIED, INCLUDING, WITHOUT LIMITATION, ANY WARRANTY OF MERCHANTABILITY OR FITNESS FOR A PARTICULAR PURPOSE, but will make available to the Buyer upon request but only to the extent permitted by law and relevant contracts, the warranties of the manufacturer of the relevant product.

1.4 Exclusions; Buyer Indemnification. The foregoing warranty shall be void with respect to defective conditions or non-conformities of the Products resulting from: (a) modifications of Products not authorized by i2Systems; (b) misuse, neglect, accident or abuse, improper wiring, repairing, splicing, alteration, installation, storage or maintenance; (c) use in a manner not in accordance with i2Systems' published operating specifications or instructions for the applicable Products; (d) Product defects caused by Buyer's combination of the Products with equipment provided or manufactured by third party vendors (unless i2Systems is advised, in writing, of such proposed combination and i2Systems thereafter consents in writing to such combination); (e) breach by Buyer or its employees, partners to whom Buyer sold Product, contractors, representatives, agents or affiliates, (collectively, "Buyer Parties") of any obligation herein; or (f) negligent use, application, installation or implementation of Product by any of the Buyer Parties. Buyer shall indemnify, defend and hold harmless i2Systems and its officers, directors, agents, employees, affiliates, representatives, successors, and assigns from and against all losses, liabilities, costs, and expenses (including, without limitation, attorneys' fees) arising out of or in connection with claims by third parties for any loss, damage, or injury (including death) caused by or alleged to be caused by the circumstances described in this Section 5.4. Buyer shall not join, settle or otherwise attempt to affect or dispose of any such claim without i2Systems' written consent.

1.5 DISCLAIMER. THE EXPRESS WARRANTIES IN THIS SECTION ARE THE ONLY WARRANTIES GRANTED BY I2SYSTEMS AND THE REMEDIES IN THIS SECTION 5 ARE THE SOLE AND EXCLUSIVE REMEDIES FOR BREACH OF SUCH WARRANTIES. EXCEPT AS EXPRESSLY PROVIDED IN THIS SECTION 1, I2SYSTEMS MAKES NO OTHER WARRANTIES, EXPRESS, IMPLIED OR STATUTORY, AND I2SYSTEMS EXPRESSLY DISCLAIMS ALL SUCH OTHER WARRANTIES, INCLUDING WITHOUT LIMITATION IMPLIED WARRANTIES OF QUALITY, CONDITION, TITLE, MERCHANTABILITY, FITNESS FOR A PARTICULAR PURPOSE AND NON-INFRINGEMENT. No agent, employee, or representative of i2Systems has any authority to bind i2Systems to any affirmation, representation or warranty concerning goods sold by i2Systems and unless an affirmation, representation or warranty is specifically included herein or in i2Systems' sales acknowledgement, it does not form a part of the basis of any bargain between i2Systems and Buyer and shall not be enforceable by Buyer.

For i2Systems complete Terms & Conditions of Sale and Warranty, please visit our website at www.i2Systems.com

